

PC Mount Common Mode Chokes

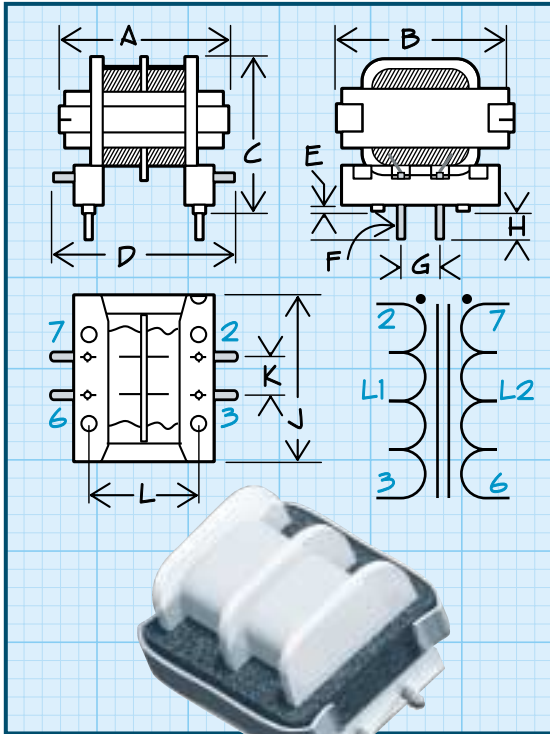

Physical Parameters

	Inches	Millimeters
A	0.740 ± 0.025	18.8 ± 0.64
B	0.840 ± 0.025	21.3 ± 0.64
C	0.670 ± 0.025	17.0 ± 0.64
D	0.900 Ref.	22.9 ± 0.64
E	0.040 ± 0.025	1.0 ± 0.64
F	0.025 Sq. (Typ.)	0.64 Sq. (Typ.)
G	0.200 ± 0.010	5.1 ± 0.3
H	0.175 ± 0.010	4.4 ± 0.3
J	0.750 ± 0.025	19.1 ± 0.64
K	0.200 ± 0.010	5.1 ± 0.3
L	0.515 ± 0.010	13.1 ± 0.3

All dimensions are typical

Operating Temperature Range -55°C to +125°C

Current Rating at 80°C Ambient 40°C rise

Mechanical Configuration Tape wrapped winding sections; varnish impregnated assembly.

- Notes**
- 1) Inductance in table is for either L1 or L2.
 - 2) Leakage Inductance tested at L1 with L2 shorted or at L2 with L1 shorted.
 - 3) Windings balanced within 1%.

Packaging Bulk only

DASH NUMBER*	L (µH), L1 or L2 @ 1kHz ± 25%	DC RESISTANCE MAXIMUM (OHMS)	CURRENT RATING MAXIMUM (AMPS)	LEAKAGE IND. MAXIMUM (µH)
-473	47	0.016	3.5	4.0
-563	56	0.018	3.5	4.0
-683	68	0.019	3.5	5.0
-823	82	0.023	2.8	5.5
-104	100	0.025	2.8	6.0
-124	120	0.028	2.8	6.5
-154	150	0.030	2.8	7.5
-184	180	0.038	2.2	8.0
-224	220	0.044	2.2	9.0
-274	270	0.051	2.2	10
-334	330	0.058	1.7	11
-474	470	0.078	1.4	16
-564	560	0.091	1.4	18
-684	680	0.115	1.1	20
-824	820	0.131	1.1	25
-105	1000	0.194	0.88	35
-125	1200	0.219	0.88	47
-155	1500	0.278	0.70	49
-185	1800	0.306	0.70	59
-225	2200	0.431	0.55	76
-275	2700	0.469	0.55	91
-335	3300	0.531	0.55	101
-395	3900	0.669	0.44	135
-475	4700	0.760	0.44	158
-565	5600	0.853	0.44	196
-685	6800	1.24	0.35	257
-825	8200	1.40	0.35	296
-106	10000	1.61	0.35	362
-126	12000	1.98	0.27	410
-156	15000	2.24	0.27	503
-186	18000	2.45	0.27	602
-226	22000	3.49	0.22	730
-276	27000	4.60	0.17	870
-336	33000	5.21	0.17	1150
-396	39000	7.19	0.13	1300
-476	47000	7.80	0.13	1541
-566	56000	8.69	0.13	1875
-686	68000	9.69	0.13	2254
-826	82000	13.10	0.10	2702
-107	100000	14.60	0.10	3269
-127	120000	16.00	0.10	3456

*Complete part # must include series # PLUS the dash #

For further surface finish information, refer to TECHNICAL section of this catalog.

TRANSFORMERS